

**ENGINEERING PLASTICS TYPE  
TOP MOUNTED LIQUID LEVEL TANK GAUGES MODELS *TP16 & TP20*  
TOP MOUNTED LEVEL SWITCHES MODELS *SP12, SP16 & SP20***

**DESCRIPTION**

KSR Kuebler USA Plastic Level Switches and Transmitters are float operated units designed for use in General Process, Water Treatment and high purity (no metal parts) applications. These units are top mounted that install through the top of the process vessel via flanged or NPT screwed connection.

All Series "SP" and "TP" units utilize the KSR Kuebler Magnetic Float design. Switches are SPDT types making it easy to specify because you do not need to know what switch action you will need because the SPDT types can be wired normally open or normally closed. This eliminates the confusion experienced with some products that offer SPST type switches. Transmitters are 4-20mA Loop Powered.

The only moving part of a KSR Plastic level sensor is the float. Direct, simple and very reliable operation.

All KSR Kuebler Plastic Level Switches and Transmitters feature long life sealed switch contacts. Special sealed reed switches are designed for millions of operations. The operating characteristics of KSR switches are low bounce and fast contact change-over. Transmitters feature 4-20mA output, making both ideal for use with modern control systems such as programmable logic controllers (PLC's) and distributed control systems (DCS's).

To optimize the life of the "SP" switch contacts, KSR Kuebler recommends employing arc suppression for **any** inductive load. Remember that inductive loads typically generate a high energy surge when switching off. This surge can be suppressed with a simple R/C network in Alternating Current loads, or with a blocking diode in Direct Current applications.

**STANDARD FEATURES**

All model "SP" switches and "TP" transmitters from KSR Kuebler offer the following standard features:

- ◆ Lengths to 200" (5000+mm).
- ◆ Wide selection of materials of construction including Kynar® and Teflon® as standard.
- ◆ Transmitters are Factory Mutual Approved Intrinsically Safe for hazardous area applications.
- ◆ Widest selection of electrical enclosures.
- ◆ 4-20mA or digital HART and Fieldbus communications available.
- ◆ Up to 6 switching points in a single unit.
- ◆ Wide selection of industrial process connections.

The above standard features allow you to select a model that best suits your process control needs, directly from this order guide. KSR Kuebler Plastic units are the highest quality and cost efficient solution to general liquid point level sensing.

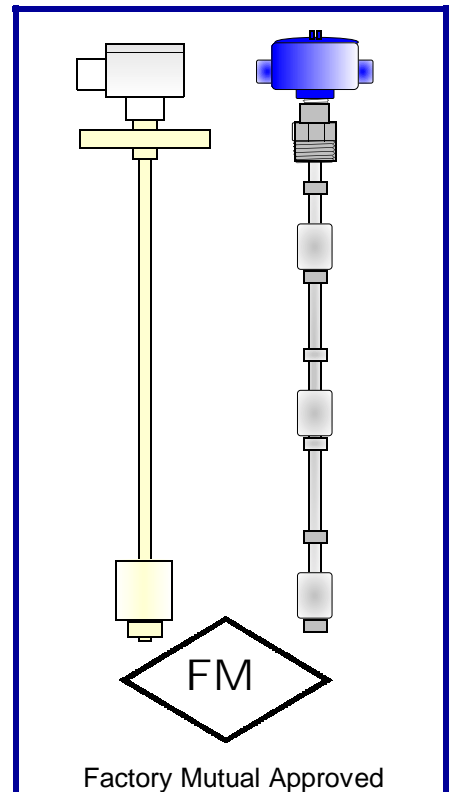

**Two Standard KSR Units**  
KSR Kuebler switch models "TP20" shown with a *standard* type NEMA 4X type enclosure (left) and a *standard* welded flange. A model "SP20" with an explosion proof (XP) type enclosure and a *standard* welded NPT connection is on the right, FM approved Intrinsically Safe for hazardous locations.

**Catalog 1003Pmini  
05/09/02 rv C**



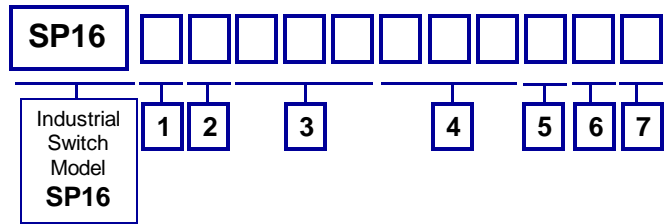
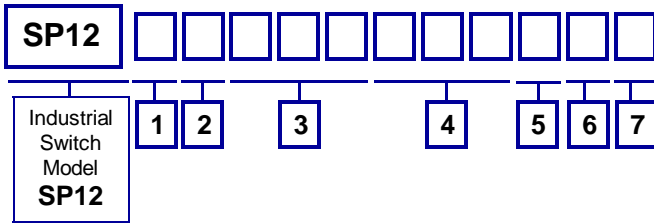

Model SP12 features a 12 mm diameter X 2mm (.078") wall thickness sensor tube.

- 1. NUMBER OF SWITCHES: 1 through 4.** Up to 4 SPDT switches are available in model SP12.
- 2. MATERIALS OF CONSTRUCTION (Wetted Parts):** V=Hard Polyvinylchloride (PVC); P= Polypropylene (PP); T= Teflon® (PTFE); K=Kynar® (PVDF).
- 3. SENSOR LENGTH:** In whole inches, up to a maximum of 60". (As measured from face of process connection to the tip of the float guide tube.) EXAMPLE: A 48" sensor would be entered as "048". When you determine the location of the last (bottom) switch, add to the sensor length 1/2 of the float height plus 1/2" minimum.
- 4. CONNECTION SIZE AND TYPE:** F10=1.0" ANSI flange; F15=1.5" ANSI flange; F20=2.0" ANSI flange; F25=2.5" ANSI flange; F30=3.0" ANSI flange; F40=4.0" ANSI flange; F50=5.0" ANSI flange; F60=6.0" ANSI flange; N05=1/2" NPT; N75=3/4" NPT; N10=1" NPT; N15=1-1/2" NPT; N20=2" NPT; NAD=3/4" NPT adjustable fitting. Flanges are Flat Face type with ANSI 150# class bolt pattern.
- 5. CONNECTION RATING\*:** A=Flange 44 PSI; D=NPT and Adjustable Fitting= 44 PSI.
- 6. ELECTRICAL HOUSING\*\*:** 1=NEMA 4X Polyester w/1/2" NPT conduit entry, 4=NEMA 4X die cast aluminum with Kuebler red epoxy coating & 1/2" NPT conduit entry; 6= Gr B explosion proof & NEMA 4X stainless steel enclosure with dual 3/4" NPT conduit entries; 7=NEMA 7 explosion proof \*\* & 4X cast aluminum with KSR blue epoxy coating & dual 3/4" NPT conduit entries; 8=Group B explosion proof\*\* & 4X stainless steel with dual 3/4" NPT conduit entries.
- 7. SWITCH TEMPERATURE RATING:** S=Standard, 0 F to +212 F maximum, depending on plastic selected.

Model SP16 features a 16 mm diameter X 2mm (.078") wall thickness sensor tube.

- 1. NUMBER OF SWITCHES: 1 through 4.** Up to 4 SPDT switches are available in model SP16.
- 2. MATERIALS OF CONSTRUCTION (Wetted Parts):** V=Hard Polyvinylchloride (PVC); P= Polypropylene (PP); T= Teflon® (PTFE); K=Kynar® (PVDF).
- 3. SENSOR LENGTH:** In whole inches, up to a maximum of 120". (As measured from face of process connection to the tip of the float guide tube.) EXAMPLE: A 48" sensor would be entered as "048". When you determine the location of the last (bottom) switch, add to the sensor length 1/2 of the float height plus 1/2" minimum.
- 4. CONNECTION SIZE AND TYPE:** F10=1.0" ANSI flange; F15=1.5" ANSI flange; F20=2.0" ANSI flange; F25=2.5" ANSI flange; F30=3.0" ANSI flange; F40=4.0" ANSI flange; F50=5.0" ANSI flange; F60=6.0" ANSI flange; N05=1/2" NPT; N75=3/4" NPT; N10=1" NPT; N15=1-1/2" NPT; N20=2" NPT; NAD=3/4" NPT adjustable fitting. Flanges are Flat Face type with ANSI 150# class bolt pattern.
- 5. CONNECTION RATING\*:** A=Flange 44 PSI; D=NPT and Adjustable Fitting= 44 PSI.
- 6. ELECTRICAL HOUSING\*\*:** 1=NEMA 4X Polyester w/1/2" NPT conduit entry, 4=NEMA 4X die cast aluminum with Kuebler red epoxy coating & 1/2" NPT conduit entry; 6= Gr B explosion proof & NEMA 4X stainless steel enclosure with dual 3/4" NPT conduit entries; 7=NEMA 7 explosion proof \*\* & 4X cast aluminum with KSR blue epoxy coating & dual 3/4" NPT conduit entries; 8=Group B explosion proof\*\* & 4X stainless steel with dual 3/4" NPT conduit entries.
- 7. SWITCH TEMPERATURE RATING:** S=Standard, 0 F to +212 F maximum, depending on plastic selected.

NOTES:

\* This pressure rating is for withstand pressure only. The float you select may lower this rating for your model "SP" switch.  
 \*\*Plastic Switch Models are NOT explosion proof approved and should not be used for explosion proof type hazardous locations. Switches used in hazardous locations must be connected to an Approved Intrinsic Safety Barrier.  
 Kynar® is a registered Trademark of Pennwalt. Teflon® is a registered Trademark of DuPont.

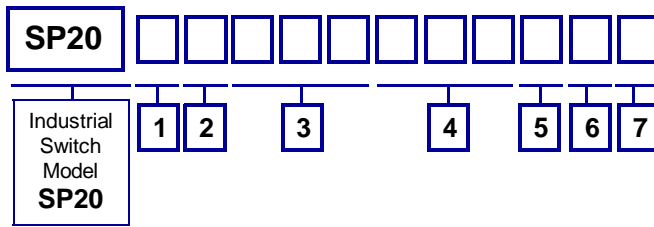

Model SP20 features a 20mm diameter X 3mm (.118") wall thickness sensor tube.

- 1. NUMBER OF SWITCHES: 1 through 6.** Up to 6 SPDT switches are available in model SP20.
- 2. MATERIALS OF CONSTRUCTION (Wetted Parts):** V=Hard Polyvinylchloride (PVC); P= Polypropylene (PP); T= Teflon® (PTFE); K=Kynar® (PVDF).
- 3. SENSOR LENGTH:** In whole inches, up to a maximum of 200". (As measured from face of process connection to the tip of the float guide tube.) EXAMPLE: A 160" sensor would be entered as "160". When you determine the location of the last (bottom) switch, add to the sensor length 1/2 of the float height plus 1" minimum.
- 4. CONNECTION SIZE AND TYPE:** F10=1.0" ANSI flange; F15=1.5" ANSI flange; F20=2.0" ANSI flange; F25=2.5" ANSI flange; F30=3.0" ANSI flange; F40=4.0" ANSI flange; F50=5.0" ANSI flange; F60=6.0" ANSI flange; N10=1" NPT; N15=1-1/2" NPT; N20=2" NPT; NAD=1" NPT adjustable fitting Flanges are Flat Face type with ANSI 150# class bolt pattern.
- 5. CONNECTION RATING\*:** A=Flange 44 PSI; D=NPT and Adjustable Fitting is 44 PSI.
- 6. ELECTRICAL HOUSING\*\*:** 1=NEMA 4X Polyester w/1/2" NPT conduit entry; 4=NEMA 4X die cast aluminum with Kuebler red epoxy coating & 1/2" NPT conduit entry; 7=NEMA 7 explosion proof \*\* & 4X cast aluminum with KSR blue epoxy coating & dual 3/4" NPT conduit entries; 8=NEMA 7 explosion proof\*\* & 4X stainless steel with dual 3/4" NPT conduit entries. 8=Group B explosion proof\*\* & 4X aluminum with dual 3/4" NPT conduit entries. **For units with +4 switches, select housing codes 6 or 9 only.**

Series "SP" Specifications	SP12	SP16	SP20
<b>Maximum Quantity of Switches</b>	4 SPDT	4 SPDT	6 SPDT
<b>Switch Current Rating A.C. / D.C. Volts</b>	1 AMP @ 120 VAC 1 AMP @ 125 VDC (non-inductive)	1 AMP @ 120 VAC 1 AMP @ 125 VDC (non-inductive)	1 AMP @ 120 VAC 1 AMP @ 125 VDC (non-inductive)
<b>Maximum Length</b>	60" (1524 mm)	120" (3048 mm)	200" (5080 mm)
<b>Termination Type</b>	PCB Mounted Terminal Block	PCB Mounted Terminal Block	PCB Mounted Terminal Block
<b>Maximum Process Pressure*</b>	NPT=44 PSI Flange=44 PSI	NPT=44 PSI Flange=44 PSI	NPT=44 PSI Flange=44 PSI
<b>Maximum Process Temperature* (switch type)</b>	+140 F type S (PVC) (Polyvinylchloride) +175 F type S (PP) (Polypropylene) +175 F type S Kynar (PVDF) +212 F type S Teflon (PTFE)	+140 F type S (PVC) (Polyvinylchloride) +175 F type S (PP) (Polypropylene) +175 F type S Kynar (PVDF) +212 F type S Teflon (PTFE)	+140 F type S (PVC) (Polyvinylchloride) +175 F type S (PP) (Polypropylene) +175 F type S Kynar (PVDF) +212 F type S Teflon (PTFE)
<b>Minimum Process Temperature (switch type)</b>	0 deg F All Switch Type SP Materials	0 deg F All Switch Type SP Materials	0 deg F All Switch Type SP Materials
<b>Float Guide Tube Diameter</b>	.47" (12 mm)	.63" (16 mm)	.79" (20 mm)
<b>Conduit Entry Size NEMA 4X</b>	1/2" NPT	1/2" NPT	1/2" NPT
<b>Conduit Entry Size Group B</b>	3/4" NPT ** (dual is standard)	3/4" NPT ** (dual is standard)	3/4" NPT ** (dual is standard)
<b>Conduit Entry S/Steel NEMA 4X &amp; Gr B</b>	3/4" NPT ** (dual is standard)	3/4" NPT ** (dual is standard)	3/4" NPT ** (dual is standard)
<b>Switch Hysteresis</b>	<.5mm (.020") typical	<.5mm (.020") typical	<.5mm (.020") typical
<b>Approvals</b>	Temperature tested and approved by FM for outdoor usage.	Temperature tested and approved by FM for outdoor usage.	Temperature tested and approved by FM for outdoor usage.

NOTES:

\* This pressure rating is for withstand pressure only. The float you select may lower this rating for your model "SP" switch.  
 \*\*Plastic Switch Models are NOT explosion proof approved and should not be used for explosion proof type hazardous locations. Switches used in hazardous locations must be connected to an Approved Intrinsic Safety Barrier.  
 Kynar® is a registered Trademark of Pennwalt. Teflon® is a registered Trademark of DuPont.

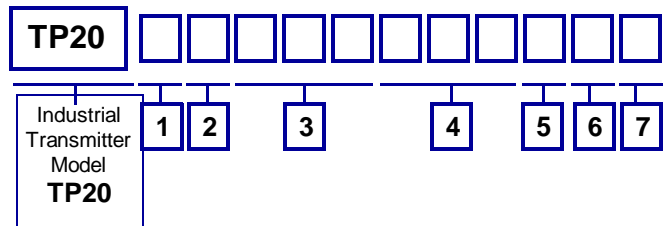
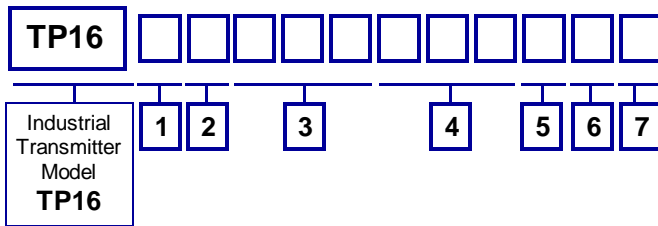

Model TP16 features a 16 mm diameter X 2 mm (.080") wall thickness sensor tube.

**1. RESOLUTION:** E=.50" (12.7mm); H=.78" (20mm).

**2. MATERIALS OF CONSTRUCTION** (Wetted Parts): V=Hard Polyvinylchloride (PVC); P= Polypropylene (PP); T= Teflon® (PTFE); K=Kynar® (PVDF).

**3. SENSOR LENGTH:** In whole inches, up to **120"**. (As measured from face of process connection to the tip of the float guide tube.) EXAMPLE: A 96" sensor would be entered as "096". When you determine the location of the last (bottom) switch, add to the sensor length 1/2 of the float height plus 1" minimum.

**4. CONNECTION SIZE AND TYPE:** F10=1.0" ANSI flange; F15=1.5" ANSI flange; F20=2.0" ANSI flange; F25=2.5" ANSI flange; F30=3.0" ANSI flange; F40=4.0" ANSI flange; F50=5.0" ANSI flange; F60=6.0" ANSI flange; N75=3/4" NPT; N10=1" NPT; N15=1-1/2" NPT; N20=2" NPT; NAD=3/4" NPT adjustable fitting; Flanges are Flat Face type with ANSI 150# bolt pattern.

**5. CONNECTION RATING\*:** A=Flange 44 PSI; D=NPT and Adjustable Fitting is 44 PSI.

**6. ELECTRONICS OPTIONS:** 0 = remote electronics, terminal block only; 1 = integral 4-20 mA loop powered with potted electronics; 3 = 24 VDC Loop Powered electronics with Integral LCD indicator with explosion proof type and NEMA 4X enclosure, cast aluminum housing with KSR Blue Epoxy coating. Choice "3" requires selecting housing option "9" below. For option "0" above, you cannot select option "9" in field "7" below.

**7. ELECTRICAL HOUSING:** 1 = Polyester Plastic NEMA 4X w/1/2" conduit entry; 3 = Group B explosion proof stainless steel with viewing window for LCD Indicator, dual 3/4" NPT conduit entries, LCD local indicator included; 4 = NEMA 4X die cast aluminum w/ Kuebler red epoxy coating & 3/4" NPT conduit entry; 7 = Group B explosion proof & NEMA 4X cast aluminum with KSR blue epoxy coating & dual 3/4" NPT conduit entries; 8 = Group B explosion proof stainless steel with dual 3/4" NPT conduit entry. 9 = Group B explosion proof cast aluminum with viewing window for LCD Indicator, dual 3/4" NPT conduit entries, KSR blue epoxy finish. LCD local indicator included.

Last, select the float that matches your process requirements. KSR Kuebler calibrates floats for interface service.

Model TP20 features an 20 mm diameter X 3 mm (.118") wall thickness sensor tube.

**1. RESOLUTION:** E=.50" (12.7mm); H=.78" (20mm).

**2. MATERIALS OF CONSTRUCTION** (Wetted Parts): V=Hard Polyvinylchloride (PVC); P= Polypropylene (PP); T= Teflon® (PTFE); K=Kynar® (PVDF).

**3. SENSOR LENGTH:** In whole inches, up to **200"**. (As measured from face of process connection to the tip of the float guide tube.) EXAMPLE: A 140" sensor would be entered as "140". When you determine the location of the last (bottom) switch, add to the sensor length 1/2 of the float height plus 1" minimum.

**4. CONNECTION SIZE AND TYPE:** F10=1.0" ANSI flange; F15=1.5" ANSI flange; F20=2.0" ANSI flange; F25=2.5" ANSI flange; F30=3.0" ANSI flange; F40=4.0" ANSI flange; F50=5.0" ANSI flange; F60=6.0" ANSI flange; N10=1" NPT; N15=1-1/2" NPT; N20=2" NPT; NAD=1" NPT adjustable fitting. Flanges are Flat Face type with ANSI 150# bolt pattern.

**5. CONNECTION RATING\*:** A=Flange 44 PSI; D=NPT and Adjustable Fitting is 44 PSI.

**6. ELECTRONICS OPTIONS:** 0 = remote electronics, terminal block only; 1 = integral 4-20 mA loop powered with potted electronics; 3 = 24 VDC Loop Powered electronics with Integral LCD indicator with explosion proof type and NEMA 4X enclosure, cast aluminum housing with KSR Blue Epoxy coating. Choice "3" requires selecting housing option "9" below. For option "0" above, you cannot select option "9" in field "7" below.

**7. ELECTRICAL HOUSING:** 1 = Polyester Plastic NEMA 4X w/1/2" conduit entry; 3 = Group B explosion proof stainless steel with viewing window for LCD Indicator, dual 3/4" NPT conduit entries, LCD local indicator included; 4 = NEMA 4X die cast aluminum w/ Kuebler red epoxy coating & 3/4" NPT conduit entry; 7 = Group B explosion proof & NEMA 4X cast aluminum with KSR blue epoxy coating & dual 3/4" NPT conduit entries; 8 = Group B explosion proof stainless steel with dual 3/4" NPT conduit entry. 9 = Group B explosion proof cast aluminum with viewing window for LCD Indicator, dual 3/4" NPT conduit entries, KSR blue epoxy finish. LCD local indicator included.

Last, select the float that matches your process requirements. KSR Kuebler calibrates floats for interface service.

NOTES:

\* This pressure rating is for withstand pressure only. The float you select may lower this rating for your model "TP" transmitter.

\*\*Plastic Models are NOT explosion proof approved and should not be used for explosion proof type hazardous locations. Transmitters used in hazardous loctions must be connected to an Approved Intrinsic Safety Barrier.

Kynar® is a registered Trademark of Pennwalt. Teflon® is a registered Trademark of DuPont.

Product Series "TP" Specifications	TP16 For Resolution See How to Order Sheet	TP20 For Resolution See How to Order Sheet
Power Supply Requirements 4-20mA Output Type	11 to 36 VDC	11 to 36 VDC
Maximum Length	120" (3048 mm)	200" (5080 mm)
Output Signal (analog)	4-20mA	4-20mA
Max. Load in Output Circuit	1000 Ohms @ 30 VDC 700 Ohms @ 24 VDC 50 Ohms @ 12 VDC	1000 Ohms @ 30 VDC 700 Ohms @ 24 VDC 50 Ohms @ 12 VDC
Maximum Process Pressure*	NPT=44 PSI Flange=44 PSI	NPT=44 PSI Flange=44 PSI
Maximum and Minimum Process Temperature	0 F to +140 F (PVC) (Polyvinylchloride) 0 F to +175 F (PP) (Polypropylene) 0 F to +175 F PVDF (Kynar) 0 F to +212 F PTFE (Teflon)	0 F to +140 F (PVC) (Polyvinylchloride) 0 F to +175 F (PP) (Polypropylene) 0 F to +175 F PVDF (Kynar) 0 F to +212 F PTFE (Teflon)
Float Guide Tube Diameter	.629" (16 mm)	.79" (20 mm)
Conduit Entry Size NEMA 4X (Aluminum Hsg)	1/2" NPT	1/2" NPT
Conduit Entry Size NEMA 4X (Polyester Hsg)	1/2" NPT	1/2" NPT
Conduit Entry Size Gr B (Small) (Cast Aluminum)	3/4" NPT ** (dual is standard)	3/4" NPT ** (dual is standard)
Conduit Entry NEMA 4X & Gr B (S/Steel)	3/4" NPT ** (dual is standard)	3/4" NPT ** (dual is standard)
Output Error	0.1% of range	0.1% of range
Factory Mutual Hazardous Area Approvals	Intrinsically Safe** Class 1, Division 1, Groups A, B, C, & D Weather proof and outdoor use rated	Intrinsically Safe** Class 1, Division 1, Groups A, B, C, & D Weather proof and outdoor use rated



DIAL toll free 1-888-KSR-LEVL for  
factory application assistance  
(1-888-577-5385)



**MODEL SERIES "SP" PLASTIC FLOATS FOR SWITCHES**

Float Part #	Float Mat'l	Float Form	Float Dia.	Float Ht.	Inner Dia.	Float S.G.	Max. Press.	Max. Temp.
SP44-S	Polyvinylchloride/ PVC	Cylinder	1.73" (44mm)	1.73" (44mm)	.55" (14mm)	.80 (0.8g/cm3)	44PSI (3Bars)	140F (60C)
SP80-S	Polyvinylchloride/ PVC	Cylinder	3.14" (80mm)	3.14" (80mm)	.98" (25mm)	.60 (0.6g/cm3)	44PSI (3Bars)	140F (60C)
SPP44-S	Polypropylene	Cylinder	1.73" (44mm)	1.73" (44mm)	.55" (14mm)	.70 (0.7g/cm3)	44PSI (3Bars)	140F (60C)
SPP80-S	Polypropylene	Cylinder	3.14" (80mm)	3.14" (80mm)	.98" (25mm)	.50 (0.5g/cm3)	44PSI (3Bars)	176F (80C)
ST55-S	Teflon PTFE	Cylinder	2.16" (55mm)	1.96" (50mm)	.51" (13mm)	.70 (0.7g/cm3)	44PSI (3Bars)	176F (80C)
ST80-S	Teflon PTFE	Cylinder	3.14" (80mm)	3.14" (80mm)	.78 (20mm)	.70 (0.7g/cm3)	44PSI (3Bars)	176F (80C)
PF55-S	Kynar PVDF	Cylinder	2.16" (55mm)	2.75" (70mm)	.74" (19mm)	.80 (0.8g/cm3)	44PSI (3Bars)	212F (100C)
PF80-S	Kynar PVDF	Cylinder	3.14" (80mm)	3.14" (80mm)	.98" (25mm)	.70 (0.7g/cm3)	44PSI (3Bars)	212F (100C)
S-S	Nitrile Rubber (Hostaform)	Cylinder	1.57" (40mm)	1.06" (27mm)	.51" (13mm)	.90 (0.9g/cm3)	Atmos.	140F (60C)

**MODEL SERIES "TP" PLASTIC FLOATS FOR TRANSMITTERS**

Float Part #	Float Mat'l	Float Form	Float Dia.	Float Ht.	Inner Dia.	Float S.G.	Max. Press.	Max. Temp.
SP80-T	Polyvinyl- chloride(PVC)	Cylinder	3.14" (80mm)	3.14" (80mm)	.98" (25mm)	.60 (0.6g/cm3)	44PSI (3Bars)	140F (60C)
SPP80-T	Polypro-pylene (PP)	Cylinder	3.14" (80mm)	3.14" (80mm)	.98" (25mm)	.50 (0.5g/cm3)	44PSI (3Bars)	176F (80C)
ST80-T	Teflon (PTFE)	Cylinder	3.14" (80mm)	3.14" (80mm)	.78 (20mm)	.70 (0.7g/cm3)	44PSI (3Bars)	176F (80C)
PF55-T	Kynar (PVDF)	Cylinder	2.16" (55mm)	2.75" (70mm)	.74" (19mm)	.80 (0.8g/cm3)	44PSI (3Bars)	212F (100C)
PF80-T	Kynar (PVDF)	Cylinder	3.14" (80mm)	3.14" (80mm)	.98" (25mm)	.70 (0.7g/cm3)	44PSI (3Bars)	212F (100C)

See More on  
the web at  
[www.ksr-usa.com](http://www.ksr-usa.com)

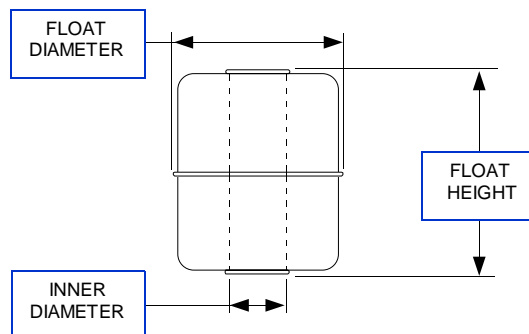

TOLL FREE 1-888-577-5385

**Fill in this form and Fax it to 1-434-374-9522 for assistance in model selection.**

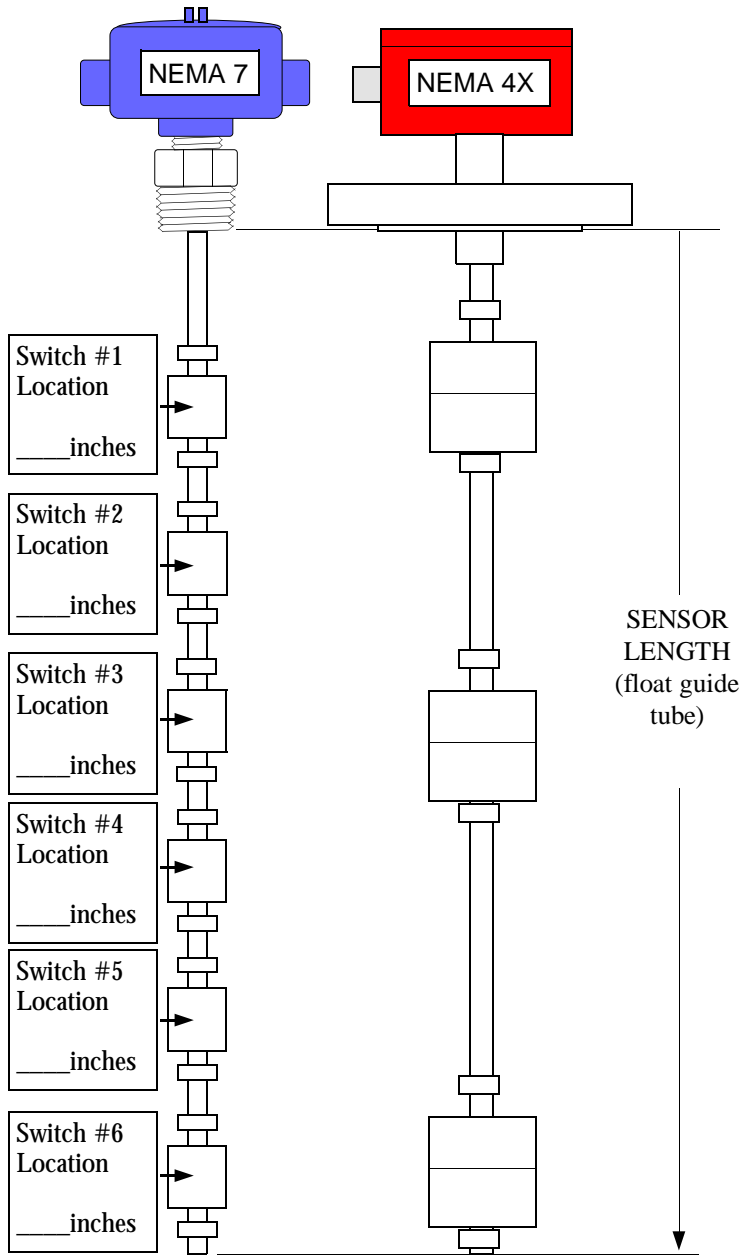

Enter the desired switch location as measured from the face of the process connection. Determine the location of the last (bottom) switch, add to the sensor length 1/2 of the float height **plus** 1/2" minimum for SP12 or 1" for SP20.

Customer Name \_\_\_\_\_  
 Customer Ref.# \_\_\_\_\_  
 KSR Model # \_\_\_\_\_

**Sensor Information**

Sensor Length \_\_\_\_\_  
 Sensor Material \_\_\_\_\_  
 Connection Type \_\_\_\_\_  
 Connection Size \_\_\_\_\_  
 Connection Rating \_\_\_\_\_  
 Max. Pressure \_\_\_\_\_  
 Max. Temp. \_\_\_\_\_  
 Min. Temp. \_\_\_\_\_  
 Liquid Name \_\_\_\_\_

**Float Information**

Float Material \_\_\_\_\_  
 Product Float #1 part# \_\_\_\_\_  
 Interface Float part# \_\_\_\_\_  
 Upper Liq. S.G. \_\_\_\_\_  
 Lower Liq. S.G. \_\_\_\_\_

**Electrical Information**

Number of Switches \_\_\_\_\_  
 Housing Type: NEMA 7 \_\_\_\_\_ NEMA 4 \_\_\_\_\_  
 Electrical Enclosure Material:  
 Alum \_\_\_\_\_ S/ Steel \_\_\_\_\_ Poly \_\_\_\_\_  
 Conduit Entry: 1/2" \_\_\_\_\_ 3/4" \_\_\_\_\_  
 Entry Quantity: 1 \_\_\_\_\_ 2 \_\_\_\_\_  
 By \_\_\_\_\_  
 Date \_\_\_\_\_

**Fill in this form and Fax it to 1-434-374-9522 for assistance in model selection.**

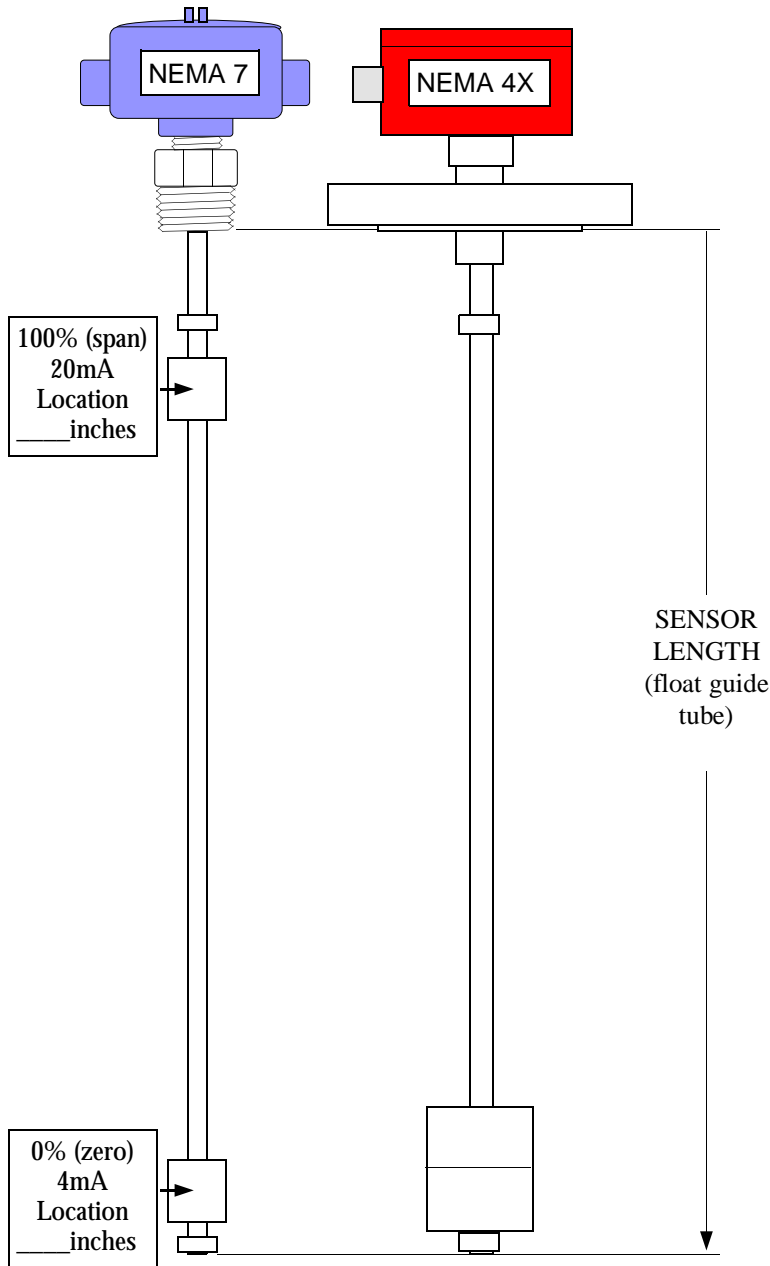

Enter the desired zero & span location as measured from the face of the process connection. Determine the location of zero (0%), add to the sensor length 1/2 of the float height plus 1" minimum.

Customer Name \_\_\_\_\_  
 Customer Ref.# \_\_\_\_\_  
 KSR Model # \_\_\_\_\_

**Sensor Information**

Sensor Length \_\_\_\_\_  
 Sensor Material \_\_\_\_\_  
 Connection Type \_\_\_\_\_  
 Connection Size \_\_\_\_\_  
 Connection Rating \_\_\_\_\_  
 Max. Pressure \_\_\_\_\_  
 Max. Temp. \_\_\_\_\_  
 Min. Temp. \_\_\_\_\_  
 Liquid Name \_\_\_\_\_

**Electrical Information**

Output Type \_\_\_\_\_  
 Housing Type: NEMA 7 \_\_\_\_\_ NEMA 4 \_\_\_\_\_  
 Electrical Enclosure Material:  
 Aluminum \_\_\_\_\_ Stainless Steel \_\_\_\_\_  
 Conduit Entry: 1/2" \_\_\_\_\_ 3/4" \_\_\_\_\_  
 Entry Quantity: 1 \_\_\_\_\_ 2 \_\_\_\_\_

**Float Information**

Float Material \_\_\_\_\_  
 Product Float #1 part# \_\_\_\_\_  
 Interface Float part# \_\_\_\_\_  
 Upper Liq. S.G. \_\_\_\_\_  
 Lower Liq. S.G. \_\_\_\_\_  
 By \_\_\_\_\_  
 Date \_\_\_\_\_